



BUILDING DEPARTMENT

190 Malabar Road SW • Suite 105 • Palm Bay, Florida 32907

Phone: 321-953-8924 •

Email: permitinfo@palmbayflorida.org

Website: <https://ims.palmbayflorida.org/ims>



TEMPORARY CONSTRUCTION POWER

A permit must be obtained from the City of Palm Bay Building Division for any “Temporary Construction Power” installation on a development site. An electrical permit should be applied for using the Building Department on-line permitting system, with "Temporary Construction Power" listed in the Permit Title field and the Permit Description field.

Permits may be obtained as described below:

- A “Temporary Construction Power” permit may be obtained AFTER the issuance of a building permit for the actual site improvements.
- A “Temporary Construction Power” permit will include two inspections. The first inspection is "Temporary Power". Upon approval of this inspection, a notice will be sent to FPL by the inspector to release power. The second inspection is the "Final Inspection". This inspection should be scheduled when the temporary power pole has been removed to close the permit out.
- Location of the temporary power pole, if not on the same lot as shown on the building permit, must be located on a subdivision site plan and submitted with the application. This procedure is applicable only to subdivision installations.

The “Temporary Construction Power” service must be installed in conformance with the National Electrical Code and Florida Power and Light electrical service standards (see next page for diagram).

Should you have any questions, please contact the City of Palm Bay Building Division at (321) 953-8924.

Temporary/Construction Service - from Overhead System (typical)

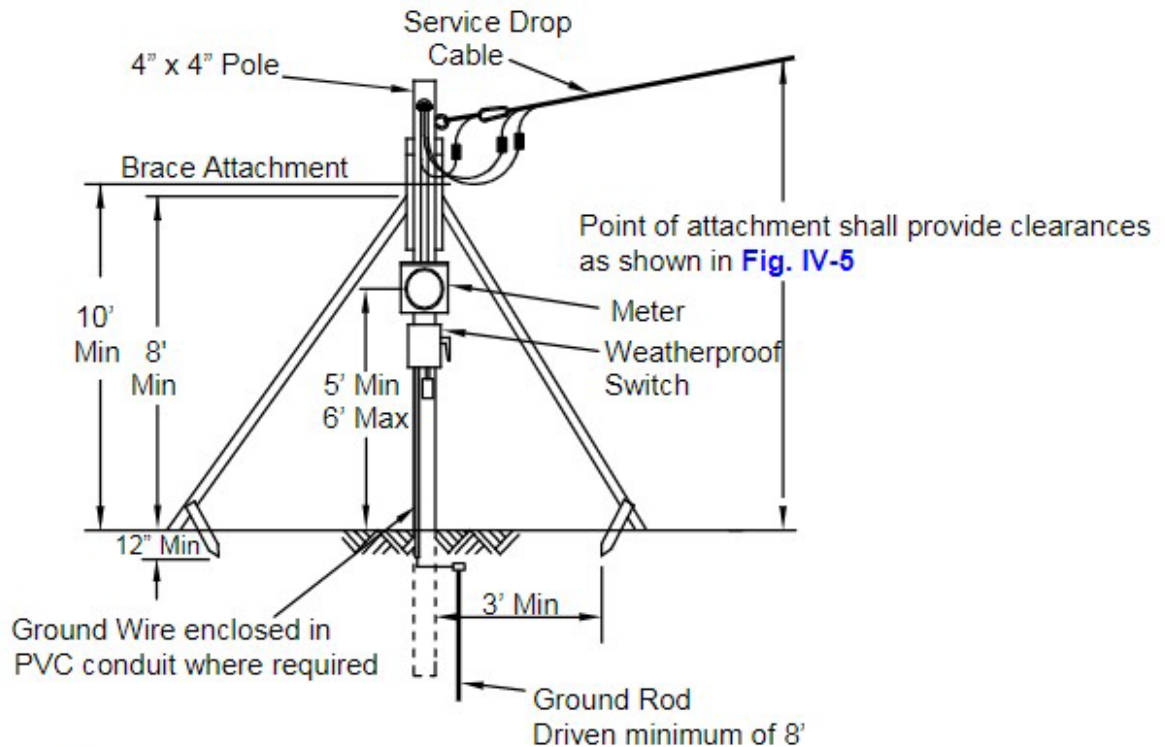
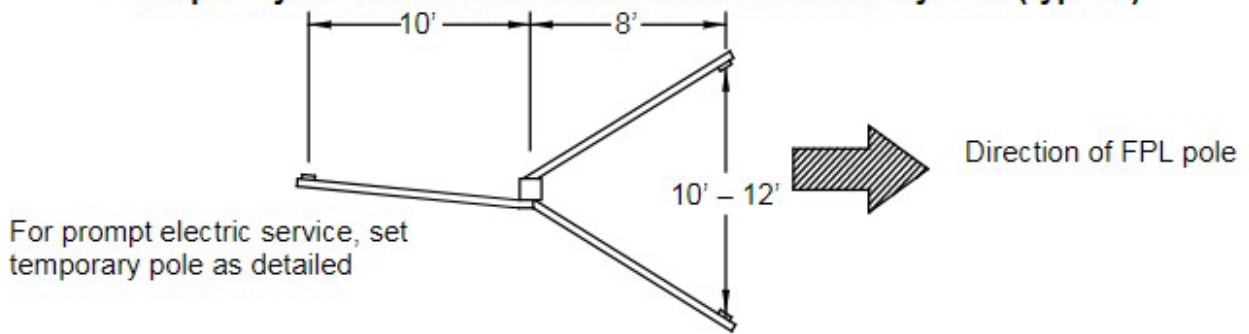

Notes:

1. Before service can be run, Company must have an electrical inspection; necessary tree trimming shall be done by the customer, and the deposit and non-refundable temporary service charge shall be paid.
2. Service pole shall not be within 25 ft. of swimming pool and must provide clearances shown in [Fig. IV-5](#).
3. Unspliced timbers are required (minimum length of 12 ft. for 2x4 braces and 16 ft. for 4x4 posts. Use ten penny (10d) nails (3" long).
4. Special arrangements shall be made with FPL if service drop exceeds 80 ft. or is larger than 200 amp capacity.
5. Minimum typical requirements are shown. If local code requirements are more stringent, they shall be adhered to.
6. The surface the meter socket is mounted on shall be plumb so the meter socket jaws are truly vertical. The meter enclosure must be on FPL's approved list.
7. Where acceptable to the inspecting authority, an 18 ft. treated pole (5" min. diameter at the top) may be substituted for the 4x4 timber and braces, provided the pole is set 5 ft. deep and well tamped. All other requirements remain the same.