

GENERAL NOTES:

1. TOP PORTION OF FTP-20-06 SHALL HAVE A REFLECTIVE BLUE BACKGROUND WITH WHITE REFLECTIVE SYMBOL AND BORDER.
2. BOTTOM PORTION OF FTP-20-06 SHALL HAVE A REFLECTIVE WHITE BACKGROUND WITH BLACK OPAQUE LEGEND AND BORDER.
3. THE SIGN SHALL BE PLACED A MINIMUM OF 3' FROM THE WHEEL STOP OR THE BACK OF CURB (WHERE APPLICABLE).

HANDICAPPED PARKING SIGN INSTALLATION DETAIL



**CITY OF PALM BAY
PUBLIC WORKS DEPARTMENT**

STANDARD SIGN DETAIL

SS - 02

DATE: APRIL 2019

APPROVED: _____

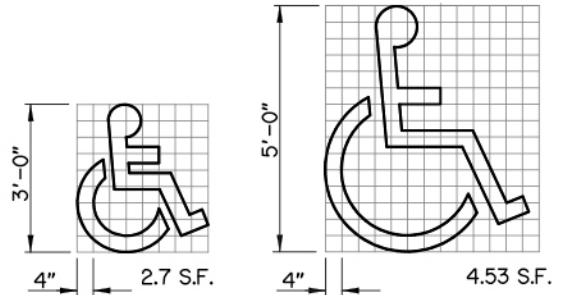
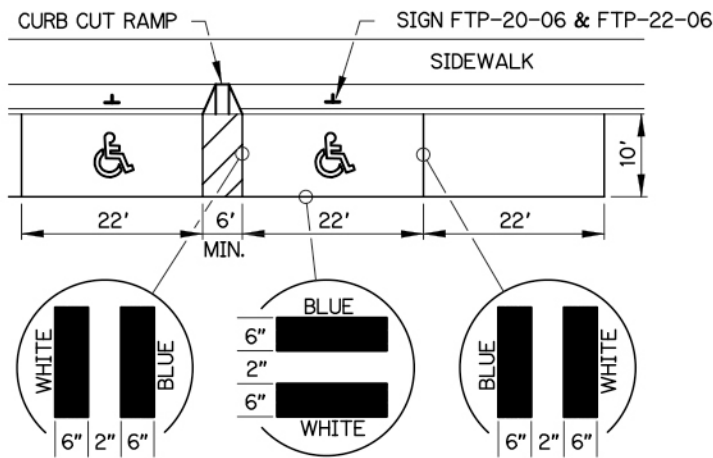

NOTE:

USE OF PAVEMENT SYMBOL IN HANDICAPPED PARKING SPACES IS OPTIONAL. WHEN USED THE SYMBOL SHALL BE 3 OR 5 FT HIGH AND WHITE IN COLOR.

HANDICAPPED PAVEMENT SYMBOL

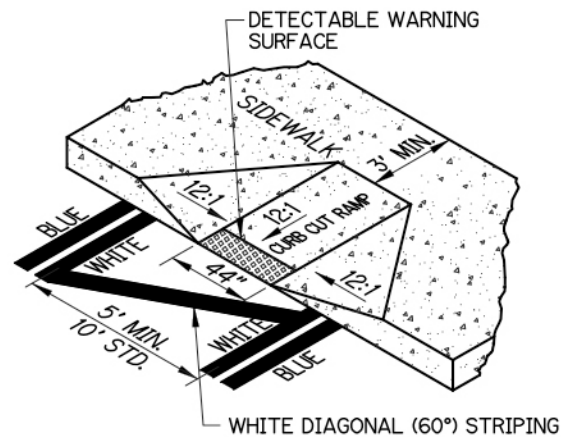
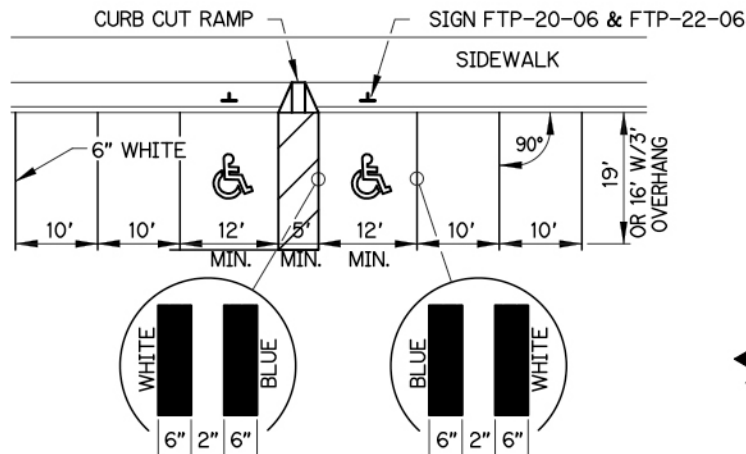

CURB CUT RAMP (TYP.)

GENERAL NOTES:

1. CRITERIA FOR PAVEMENT MARKINGS ONLY, NOT CURB CUT RAMP LOCATIONS. FOR RAMP CRITERIA SEE FDOT INDEX NO. 304.
2. BLUE PAVEMENT MARKINGS SHALL BE TINTED TO MATCH SHADE 15180 OF FEDERAL STANDARD 595a.
3. ALL CURBS OR CURBSTOPS SHOWN ARE OPTIONAL.
4. FOR ANGLED PARKING, REFER TO FDOT ROADWAY AND TRAFFIC DESIGN STANDARDS INDEX NO. 17346.

HANDICAPPED RAMP AND PAVEMENT MARKING DETAIL



**CITY OF PALM BAY
PUBLIC WORKS DEPARTMENT**

STANDARD SIGN DETAIL

SS - 03

DATE: APRIL 2019

APPROVED: _____

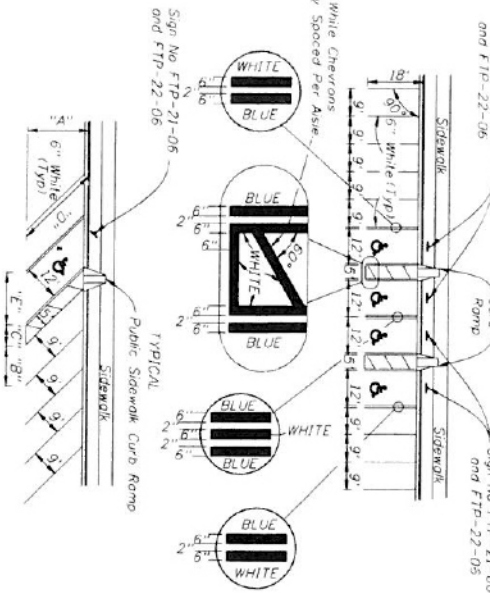
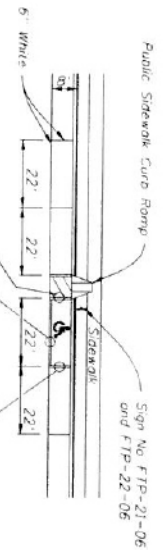

FOR ACCESSIBLE MARKINGS - SEE ABOVE

ANGLE	"A"	"B"	"C"	"D"	"E"
45°	19'-1"	12'-9"	7'-0"	27'-0"	17'-0"
60°	20'-1"	10'-5"	5'-9"	23'-2"	13'-10"

- NOTES:
- Dimensions are to the centerline of markings.
 - An access aisle is required for each accessible space when angle parking is used.
 - Criteria for pavement markings only, not public sidewalk curb ramp locations.
 - Curb ramp locations refer to plans.
 - Blue pavement markings shall be tinted to match shade 15180 of Federal Standard S85c.
 - The FTP-22-06 panels shall be mounted below the FTP-21-06 sign.

PAVEMENT MARKING FOR PUBLIC SIDEWALK CURB RAMPS IN REST AREAS

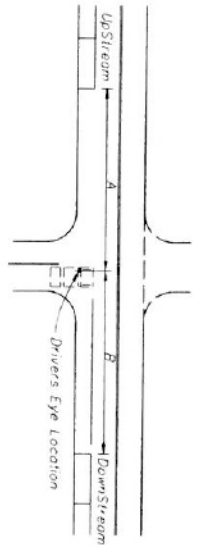

SPEED MPH	DOWN STREET (B)	
	UP STREET (A)	DOWN STREET (B)
0-30	85'	60'
35	100'	70'

- NOTES:
- Distances measured longitudinally along the street from driver location of entering vehicle to end of parking restriction.
 - Distances applicable to intersecting street, major driveways and other driveways to the extent practical.
 - For nonsignaled intersections, the values above shall be compared with the values for signaled intersections and the maximum restrictions implemented. These restrictions apply to both accessible and non-accessible parking.

MINIMUM PARKING RESTRICTION FOR NONSIGNALIZED INTERSECTIONS

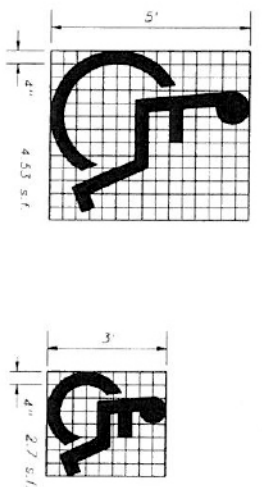

6. Use of pavement symbol in accessible parking spaces is optional, when used the symbol shall be 3'-0" high and white in color.

UNIVERSAL SYMBOL OF ACCESSIBILITY

MINIMUM PARKING RESTRICTION FOR SIGNALIZED INTERSECTION

SPEED LIMIT MPH	SIGNALIZED INTERSECTIONS	DISTANCE FROM CURB RADIUS (Y)
0-30	30'	
35	50'	

- NOTES:
- Parking restrictions measured from curb radius point.
 - Restrictions for accessible parking are the same as those applied to nonsignaled intersections.

MINIMUM PARKING RESTRICTION FOR SIGNALIZED INTERSECTION

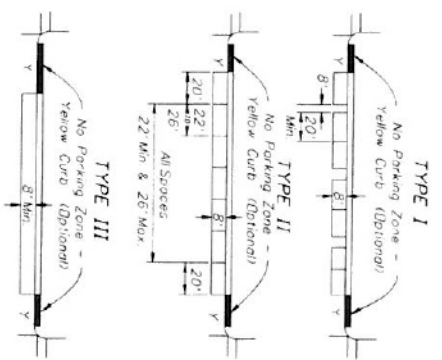

- GENERAL NOTES (Signalized & Nonsignalized)
- For entrances to a one-way street, the downstream restriction may be reduced to 20'.
 - Parking shall not be allowed within 20' of a crosswalk.
 - All parking lane markings shall be 6" white.
 - Parking lane lines shall be broken at driveways.
 - Refer to Chapter 515, Fla. Statutes, for laws governing parking spaces.
 - Where curb and gutter is used, the gutter pan width may be included as part of the minimum width of parking lane, but thereby the lane width should be in addition to that of the gutter pan.



SPECIAL MARKING AREAS (PARKING)

2010 FDOT Design Standards